

4EB1000

Hydraulic 2-post lifts with semi-base 4.000 kg

Suitable for any type of cars and repairs



SPECIFICATIONS

| | |
|------------------------|--|
| Distance between posts | 2.700 mm. |
| Load capacity | 4.000 kg. |
| Pick up height | 90 mm. |
| Pads height | 70 & 140 mm |
| Max. Lifting height | 1.980 mm |
| Lifting time | 45 s |
| Arms length (min-max) | 800-1235 mm |
| Overall width | 3.415 mm. |
| Motor | 3 phases 230-400 V 50/60 Hz. 2.2 KW |

Single Phase version: **4EB1051**

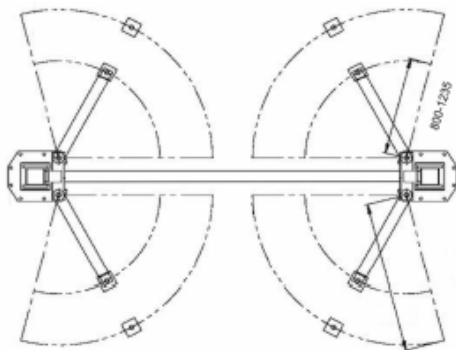
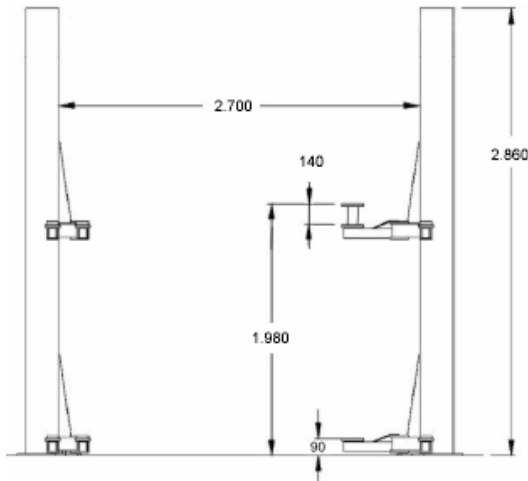

GENERAL FEATURES & SAFETY SYSTEMS

- Homologated and certified product according to the European Directive 2006/42/CE.
- 3-stage arms with low pick-up height 90 mm.
- Enforced carriage & arm for better safety
- Carriage synchronization and safety against obstacles by wire.
- Automatic arms blockage
- Three phases ON/OFF isolation switch
- Manual release of safety locks
- Two chains of 3 times cargo capacity drive the carriages ensuring a total safety.
- Semi-base low profile: 34 mm height
- Two adaptor extension kits (70 & 140 mm) permit the loading of any type of vehicle.
- Toe guard device on lifting arms

SPECIAL OPTIONAL

| Part Number | Description |
|----------------|---|
| 994000 | Anchorage steel plate |
| 4252200 | Extra-long arms set (2 arms per set) Dimensions: min/max 950-1450 mm |
| 4252300 | Extra-short arms set (2 arms per set) Dimensions : min/max 600-1150 mm |
| 003937 | Reinforced packaging |

3-stage arms



Lifts can be originally supplied from factory with extra short/long arm sets on order.



TRADEMARK AWARD
HONOURING THE TOP
QUALITY AND BEST
SERVICE IN VEHICLE LIFTS

