

## 4EC0500

Electromechanical 2-post lifts baseless 3.000 kg. Asymmetric arms

Electronic Synchronization



Distance between posts	2.500 mm.
Load capacity	3.000 kg.
Pick up height	105 mm.
Pads height	95 mm
Max. Lifting height	1.950 mm
Lifting time	55 s
Arms length (min-max)	Short: 580-820 mm Long: 810-1.250 mm
Overall width	3.118 mm
Motor	2 X 3 phases 230/400 V 50/60 Hz. 1,5 KW

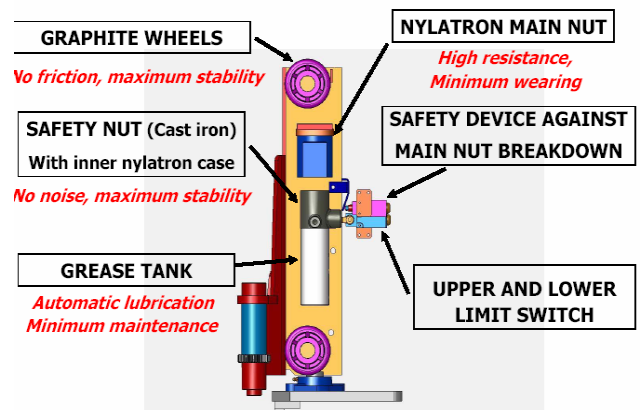

3 phases 60 Hz version: **4EC0562**

### GENERAL FEATURES

- Asymmetric arms permit an easy open of doors.
- **Homologated and certified** product according to the European Directive 2006/42/CE.
- **SCS** is the new self-diagnostic and integrated informative system for vehicle lifts.
- **Easy to enter the** vehicle without any effort or to introduce it without tool bench or other auxiliary equipment.
- **Low maintenance:** Automatic and permanent lubrication of the spindles and nuts.
- **Maximum stability:** No block sliders. Each carriage is equipped with four wheels to guarantee the minimum friction inside columns permitting a stable lifting and lowering.
- **High resistant spindles** made of special laminated steel and a nut system of long-life.
- Manual lowering of arms in case of energy absence.



TRADEMARK AWARD  
HONOURING THE TOP  
QUALITY AND BEST  
SERVICE IN VEHICLE LIFTS



## 4EC0500

Electromechanical 2-post lifts baseless 3.000 kg. Asymmetric arms

### SAFETY SYSTEMS:

- **Safety system** against obstacles on lowering.
- **Safety device** against breakage or wear of main nut.
- Automatic arms blockage.
- **Thermal detector** on motor against overheating.
- Upper and lower height limit switches.
- **Push buttons at 24 V**, type "dead man" safety control, separated switches up/down.
- Products tested before delivery from factory.



**SCS** is the new self-diagnostic and integrated informative system for vehicle lifts. This system analyses the mechanical and electrical state of lifts and it helps not only the breakdown prevention but the decrease of repair expenses as well. It is also a useful guide to be used by the technical assistance services.

**SCS** is the most innovative and intelligent informative system for vehicle lifts offering exclusively the following advantages all together:

- Spot information about lift height.
- Pre-set service for automatic height stop.
- Maintenance service warning sign.
- General revision warning sign.
- Components information service

**VELYEN**, European leader trademark, is the pioneer which apply this exclusive informative system **SCS** to a new generation of vehicle lifts.

### TECHNICAL DRAWINGS

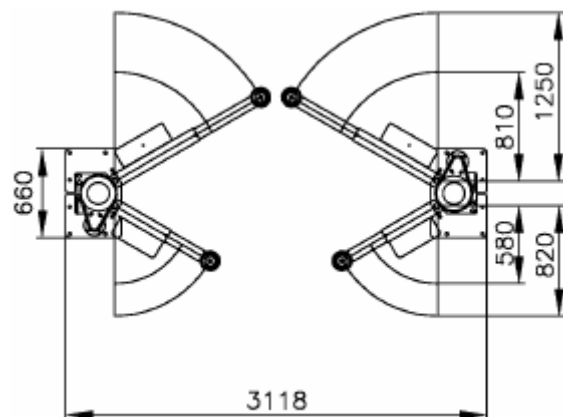
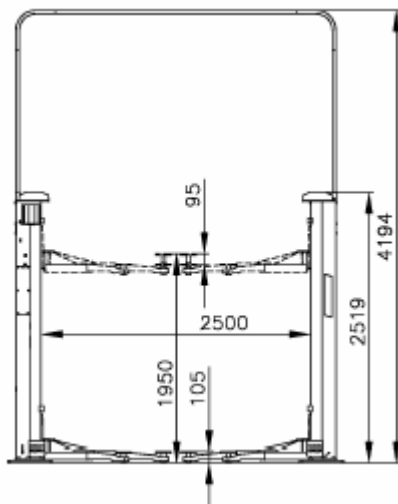

TRADEMARK AWARD  
HONOURING THE TOP  
QUALITY AND BEST  
SERVICE IN VEHICLE LIFTS

