

4ED0100

Hydraulic 4-post lifts 3.200 kg for passenger cars



TECHNICAL SPECIFICATIONS:

Load capacity	3.200 Kg
Platform length	4.080 mm
Platform width	395 mm
Distance between posts	2.385 mm
Distance between platforms	Min/Max 800-1205 mm
Maximum lifting height	1.700 mm
Drive on height	190 mm
Lifting time	30 s
Motor	2.2 Kw – Three Phases 230/400V – 50/60 Hz
Overall length	5.010 mm
Overall width	2.750 mm

Single phase version: **4ED0151** (1.9Kw – 230V)

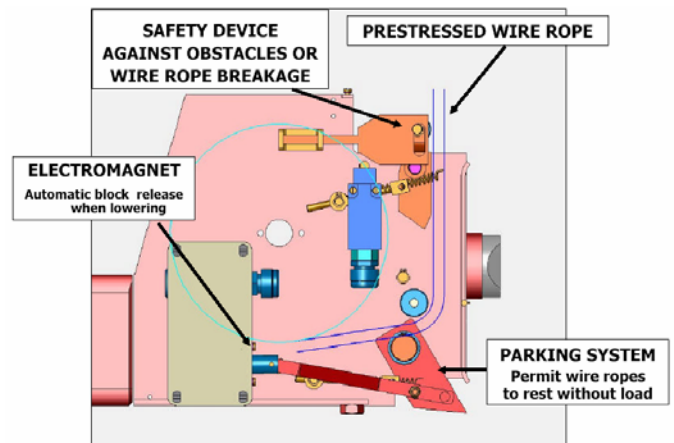

GENERAL FEATURES

- Homologated and certified product according to the European Directive 2006/42/CE.
- Electro-hydraulic lifting system operating over a simple effect cylinder.
- Innovative design of columns without longitudinal welds.
- Parking system of platforms by automatic electromagnets.
- Automatic release of safety wedges by pushing "DOWN" pushbutton
- Movable piston or scissor jacking beam available on order
- Flanged platforms

SAFETY SYSTEMS:

- Safety system against obstacles on lowering.
- Height limit: mechanical stop limits the run of piston.
- Hydraulic cylinder with control valve of lowering speed.
- Safety device against cable breakage or looseness.
- Hydraulic safety valve against overpressure.
- Thermal detector on motor against overheating.
- Push buttons at 24 V, type "dead man" safety control, separated switches up/down.



TRADEMARK AWARD
HONOURING THE TOP
QUALITY AND BEST
SERVICE IN VEHICLE LIFTS



4ED0100

Hydraulic 4-post lifts 3.200 Kg for passenger cars

TECHNICAL DRAWINGS

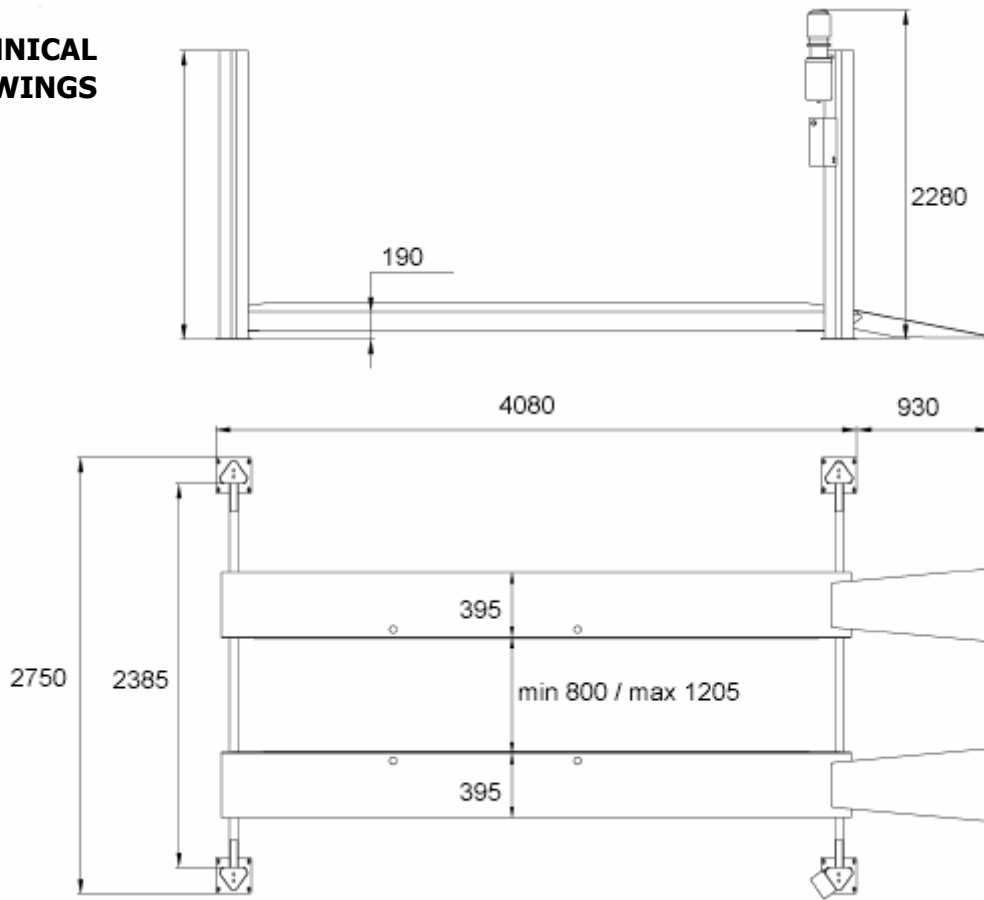

OPTIONAL ACCESSORIES



P/N 4221000
INSP. LAMP



P/N 999988
PLATFORM LIGHT



P/N 999991
TOOL SUPPORT



P/N 4249800 + 4249900
PISTON JACK BEAM 2t



P/N 4741600
AIR/ENERGY



P/N 4741600
ALIGNMENT SUPPORT



P/N 4661600
SLIDING REAR PLATFORMS



P/N 5251100
SCISSOR JACK BEAM 2t



P/N 4370500
EXIT RAMP SET



TRADEMARK AWARD
HONOURING THE TOP
QUALITY AND BEST
SERVICE IN VEHICLE LIFTS

