

4EB0600

Electromechanical 2-post lifts with base 3.000 kg. Symmetric arms

Suitable for any type of cars and repairs



Distance between posts	2.500 mm.
Load capacity	3.000 kg.
Pick up height	105 mm.
Pads height	130 mm
Max. Lifting height	1.985 mm
Lifting time	55 s
Arms length (min-max)	730 – 1100 mm
Overall width	3.000 mm.
Motor	3 phases 230/400 V 50 Hz. 3 KW

Single Phase version: **4EB0651 – 2.8t**

3 phases 60 Hz version: **4EB0662**

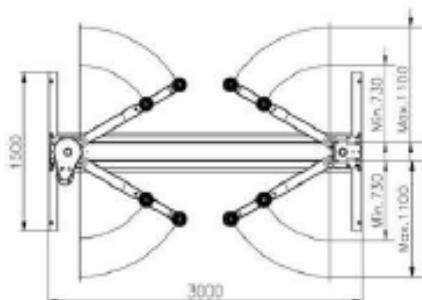
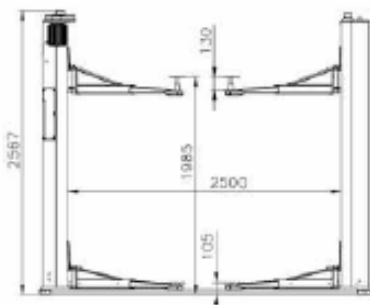
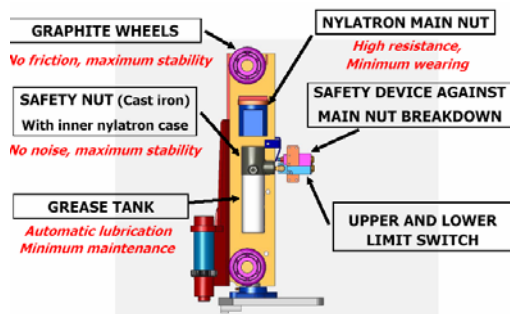

GENERAL FEATURES & SAFETY SYSTEMS

- **Homologated and certified** product according to the European Directive 2006/42/CE.
- **Maximum resistance:** "T" Innovative bending design of columns without longitudinal welds.
- **No wearing:** main nut made of Nylatron.
- **Minimum noise:** Nylatron case fitted inside safety nut..
- **Low maintenance:** Automatic and permanent lubrication of the spindles and nuts.
- **Maximum stability:** No block sliders. Each carriage is equipped with four wheels to guarantee the minimum friction inside columns permitting a stable lifting and lowering.
- Safety system against obstacles on lowering
- Safety device against breakage or wear of main nut.
- Automatic arms blockage.
- Thermal detector on motor against overheating.
- Upper and lower height limit switches.
- High resistant spindles made of special laminated steel.
- Manual lowering of arms in case of energy absence.
- Safety mechanism against breakage or looseness of the drive chain.
- Push buttons at 24 V, type "dead man" safety control, separated switches up/down.
- Products tested before delivery from factory.



TRADEMARK AWARD
HONOURING THE TOP
QUALITY AND BEST
SERVICE IN VEHICLE LIFTS

