

4EB1000

Hydraulic 2-post lifts with semi-base 4.200 kg

Suitable for any type of cars and repairs



SPECIFICATIONS

Distance between posts	2.700 mm.
Load capacity	4.200 kg.
Pick up height	90 mm.
Pads height	70-140-220 mm
Max. Lifting height	2.060 mm
Lifting time	40 s
Arms length (min-max)	800-1235 mm
Overall width	3.000 mm.
Motor	3 phases 220-400 V 50/60 Hz. 2.2 KW

Single Phase version: **4EB1051**

GENERAL FEATURES & SAFETY SYSTEMS

- Homologated and certified product according to the European Directive 2006/42/CE.
- 3-stage arms with low pick-up height 90 mm.
- Enforced carriage & arm for better safety
- Carriage synchronization and safety against obstacles by wire.
- Automatic arms blockage
- Three phases ON/OFF isolation switch
- Manual release of safety locks
- Two chains of 3 times cargo capacity drive the carriages ensuring a total safety.
- Semi-base low profile: 34 mm height
- Two adaptor extension kits (70-140-220 mm) permit the loading of any type of vehicle.
- Toe guard device on lifting arms

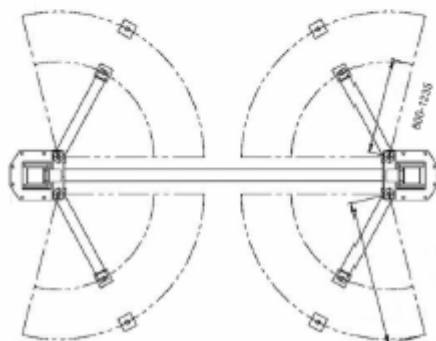
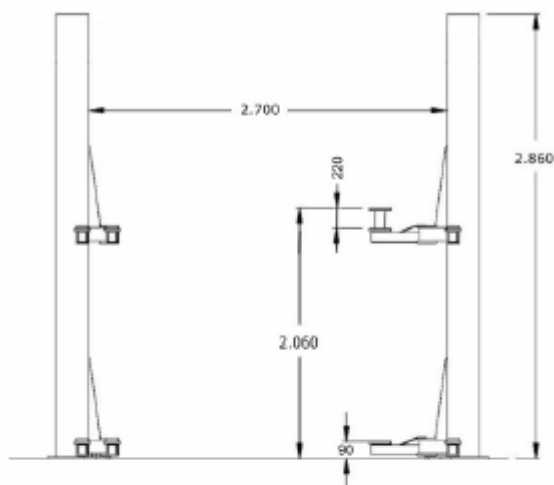

SPECIAL OPTIONAL

Part Number	Description
994000	Anchorage steel plate
4252200	Extra-long arms set (2 arms per set) Dimensions: min/max 990-1410 mm
4252300	Extra-short arms set (2 arms per set) Dimensions : min/max 620-1100 mm
003937	Reinforced packaging

3-stage arms

