

4EC1100

Hydraulic 2-post lifts baseless 4.500 kg. Symmetric arms

Suitable for any type of cars and repairs



| | |
|------------------------|------------------------------------|
| Distance between posts | 2.970 mm. |
| Load capacity | 4.500 kg. |
| Pick up height | 90 mm. |
| Pads height | 140 mm |
| Max. Lifting height | 2.010 mm |
| Lifting time | 45 s |
| Crossbeam bar height | 4.610 mm |
| Arms length (min-max) | 820-1300 mm |
| Overall width | 3.683 mm |
| Overall height | 4.750 mm |
| Motor | 3 phases 400 V 50/60 Hz. 2.2 KW |

Single Phase version: **4EC1051**

GENERAL FEATURES & SAFETY SYSTEMS

- Homologated and certified product according to the European Directive 2006/42/CE.
- Extra wide drive through clearance for large commercial vehicles.
- Long carriages for a safety lifting and large durability.
- 14-step safety locks guarantee an automatic protection system.
- Automatic arms blockage.
- Two direct drive hydraulic cylinders ensure the maximum stability.
- Single point release of safety locks make this lift easy and safe to use.
- Carriage synchronization and safety against obstacles by wireropes.
- Three phases ON/OFF isolation switch
- 2nd floor mounting plate available on order
- Two adaptor extension kits (70 & 140 mm) permit the loading of any type of vehicle.

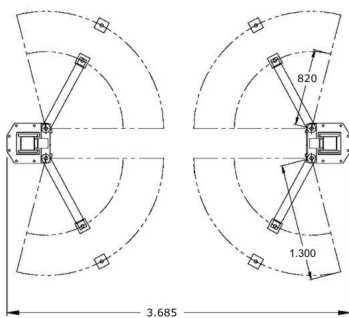
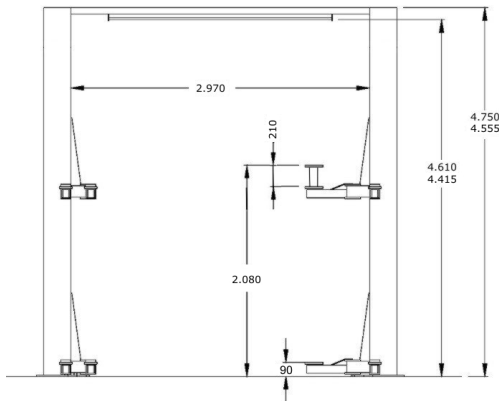

SPECIAL OPTIONAL

| Part Number | Description |
|----------------|--|
| 993900 | Toe guard kit |
| 993700 | Voltage change kit from 400V to 230V |
| 4252200 | Extra large arms kit (2 arms per kit) Dimensions: min/max 990-1410 mm |
| 003939 | Reinforced packaging |

